

Action code: AT FIRST OPPORTUNITY

**Piston cleaning ring**

Update of the instruction for piston cleaning ring replacement  
Replacement of SL2016-620/AAB

SL2019-684/JAP  
November 2019

**Concerns**

Owners and operators of MAN B&W two-stroke marine diesel engines.  
Type: All MAN B&W engines fitted with piston cleaning ring.

**Summary**

Update of the instructions for operating the engine with a PC-ring when the liner is worn.

Other relevant Service Letters are:  
SL2000-382

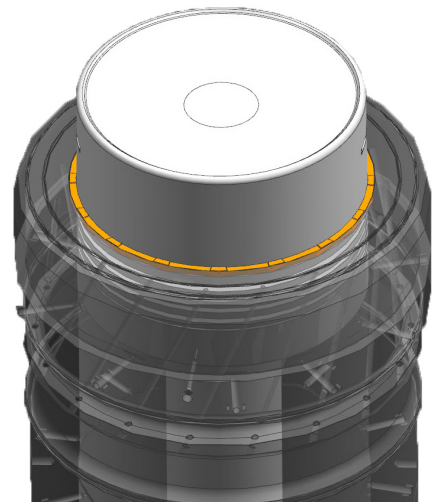

Dear Sir or Madam

It has come to our attention that misunderstandings have occurred regarding piston cleaning ring (PC ring) replacement when a liner is worn. The PC ring replacement instruction has therefore been updated.

The piston cleaning ring is installed to protect against excessive deposit build-up on the piston crown top land by scraping off the deposits when the piston approaches top dead center (TDC).

If deposits build up excessively on the top-land of the piston crown, it can have a negative influence on the cylinder condition. It is therefore not recommended to operate the engine without the PC ring installed.

For questions or inquiries regarding the content in this service letter, contact our Operation Department at: [Operation2S@man-es.com](mailto:Operation2S@man-es.com)

Yours faithfully

**Mikael C. Jensen**  
Vice President, Engineering

**Stig B. Jakobsen**  
Senior Manager, Operation

**Introduction**

The piston cleaning ring (PC ring) was introduced to the engine design to prevent excessive deposit build-up on the piston crown top land.

The PC-ring dimensions prevent excessive deposits on the top land by its inner diameter spacing the top land when the piston approaches TDC during each stroke.

The piston crown top land height has increased over time to secure the cylinder condition. Because of the increased top land dimensions, deposits on the top land have become more critical than for shorter top land engines.

**Cylinder overhaul**

The PC ring and cylinder liner are designed to always follow each other. Therefore, when a cylinder unit is overhauled, the PC ring must be inspected, cleaned and if intact, reused.

If the PC ring is removed from the liner for some reason, it is important to mark the correct position on the parts. The PC ring must be installed in the same position as when removed, because it is worn together with the cylinder liner.

Since the PC ring is worn to the same extent as the liner, it is not necessary to replace the PC ring during overhaul.

**New liner**

When installing a new liner, it is mandatory to install a new PC ring too.

**Reconditioned liner**

When installing a reconditioned liner (when the liner is worn beyond the defined critical dimension in the skirt TDC position) a PC ring must be installed which matches the new bore diameter, and it must follow the liner as they are a matched item.

**Operation WITHOUT a PC ring (not recommended)**

Since the function of the PC ring is to protect against deposits building up on the piston crown top land, operation without a PC ring can lead to excessive deposit formation on the top land.

Deposits on the top land can have a negative impact on the condition of the unit. It may cause polishing of the liner surface and also lead to a lack of lubrication between the piston rings and liner, which eventually can result in piston ring or piston skirt scuffing.

A deposit build-up can also affect the position of the piston inside the cylinder and cause high friction between the liner and piston skirt. This situation may lead to severe damage of the liner and skirt, and must be avoided.

Operation without a PC ring cannot be recommended and is only allowed in emergency situations when no PC ring is available. The condition should be rectified as soon as possible.

**Instruction book**

A review of our previous instruction for cylinder overhaul and PC ring evaluation has deemed it necessary to send out this update, and to give the clear instruction not to remove the PC ring unless it is damaged to an extent where it can no longer be used. The revised instruction has been included on pages 3 and 4.

If the PC ring has to be renewed because of damage, a new one can be fitted to a worn liner provided that the liner wear in the piston skirt TDC position is less than 0.1% of the bore diameter. The instruction on pages 3 and 4 shows the definition of the skirt TDC position and how to measure it.

Note, that the evaluation of the liner wear must NOT be based on the liner maximum wear but on the wear measured in the the piston skirt TDC.

If the PC ring is broken or damaged and the liner wear exceeds 0.1% in the piston skirt TDC position, please contact MAN Energy Solutions for further guidance.

If for some reason it is not possible to exchange the liner, MAN Energy Solutions should be consulted for guidance on how to proceed.

**Checking**

1. Preparation Dismount the cylinder cover and the piston.  
See work card 2265-0301 and 2265-0401.

2. Piston Skirt Check Distance On the removed piston (or a spare piston) measure the check distance X from the upper edge of the top ring groove to the middle of the piston skirt.

Note down the check distance X.

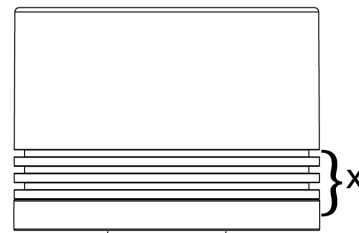

2265-0601-0031C02

3. Taking liner measurements Position the cylinder liner measuring tool.

For detailed information on taking cylinder wear measurements and assessing liner condition, See description 2245-0100, item 4.5

Check and assess the condition of the cylinder liner.

For new cylinder diameter, See data T22-107.

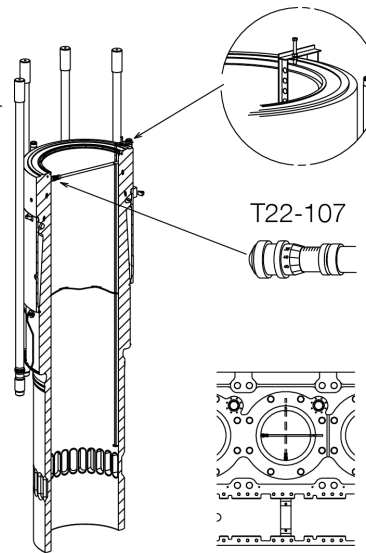

2265-0601-0004C02

**Checking**

**Piston Cleaning Ring**

Work Card

2265-2207-0001

MAN Energy Solutions

Checking

4. Piston Skirt TDC

In addition to the measuring points visible on the cylinder liner measuring tool, measurements must also be taken at the Piston Skirt TDC position.

The Piston Skirt TDC position is located X mm below the wear ridge created at the top piston ring TDC. For calculation of X see step 2 "Piston Skirt Check Distance".

Using a paint marker or similar make a mark at the Piston Skirt TDC position and measure the liner diameter in this position for calculation of liner wear.

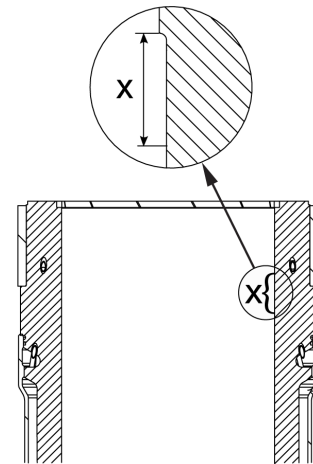

2265-0601-0031C05

5. Piston cleaning (PC) ring

When removing the piston cleaning (PC) ring between the liner and the cylinder cover, make sure to mark the position of the ring to allow fitting of the PC-ring in the same position as it is worn together with the liner.

The PC-ring is to be regarded as an integrated part of the liner and it is intended to follow the service life of the liner.

During inspection of the piston and the liner, the PC-ring must also be inspected.

For the piston cleaning ring measurements, see Data T22-108 and T22-109

NOTE !

- If the PC-ring is undamaged, re-mount the PC-ring in the cylinder liner in the original position (Scratch marks, made before removal, must align).
- If the PC-ring is broken or cracked and the cylinder liner wear (measured **at the Piston Skirt TDC position**) is **below** 0.1% of the nominal diameter, replace the PC-ring with a new standard PC-ring.
- If the PC-ring is broken or cracked **and** the cylinder liner wear (measured **at the Piston Skirt TDC position**) is **above** 0.1% of the nominal diameter, contact MAN Energy Solutions.

When a new cylinder liner is installed, a new PC-ring must also be installed. When a new liner is ordered, a new PC-ring must also be ordered.

Piston Cleaning Ring

Work Card